

**MIRAGE<sup>®</sup>**  
POP-UP DISPLAY

**Skyline<sup>®</sup>**



Mirage<sup>®</sup> Pop-Up Display —  
The Legendary Pop-Up





# The World's Best Pop-Up

Mirage® pop-up frame is the most durable available. If impacted, the fiberglass Mirage display frame will flex and bounce back without damage, unlike aluminum. Mirage displays perform every time and will not leave you stuck at a show with a frame that's damaged or bent. That's peace of mind. **Mirage display frame and channels have a lifetime warranty.**

## Pop-Up Portability

Great look and convenience. Mirage pop-up displays give you a classic curved look and uninterrupted graphics for a big brand presence. Its fiberglass frame has both magnetic and mechanical connectors, which makes Mirage easy to set up and very stable.

A variety of accessories are available including monitor mounts, shelving, headers and more.



## Highest Quality Graphics

Make an impression on clients and prospects with the highest quality, longest lasting graphics. Skyline graphics are produced in house for the very best fit and finish. Unlike other pop-ups, Mirage display channels feature special magnetic strips that provide perfect graphic alignment for a truly seamless appearance.



## Big Impact In Smaller Spaces

Attract attendees with Mirage tabletop displays. They are available in multiple widths and heights, pack in a single case and install with ease.

*"We were looking for an exhibit that was consistent in quality with the products and services we offer."* – Big Bear Promotions



## Bubble Panel

Bubble Panel gives Mirage a new look and can be backlit to attract attention. Bubble Panel easily installs with magnets.

*"Our latest trade show was a huge success, and Skyline was a major factor."* – John Deere-Green Tech



## Protective Cases

Mirage displays pack neatly in protective cases. A 10' (3 m) display fits in either a single Hard case, two Oval cases or two Transporter cases. All cases have handles and wheels for easy transport.

## Convex Back Panels

Mirage displays are designed to accommodate graphics on both front and back for island applications.



## Backlighting Attracts

Mirage can be backlit with Skyline LED lighting to attract attention to your brand and message.



# Versatile Mirage® Displays Fit Any Space

Mirage displays are available in several sizes from tabletops to full 10' (3 m) units. Larger inline exhibits are created by seamlessly connecting units together. Mirage displays can also be configured to create 3- or 4-sided island exhibits.



## Monitor Mount For Digital Presentations

Mount up to two 15 lb. monitors or up to four 10 lb. monitors on a 10' curved Mirage.



## Convenient Case Table

Transform your cases into a branded workstation. Table top and panels attach quickly and easily with magnets.



## LED Arm Lights

24W LED rivals the brightness of a 200W halogen lamp, but uses 88% less energy! It is also more durable and can be repacked sooner than halogen.

## Mirage® Display Models

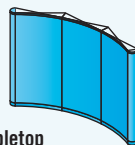

6' 52" Tabletop

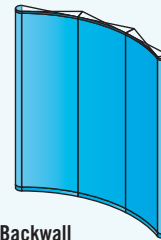

8' 92" Backwall

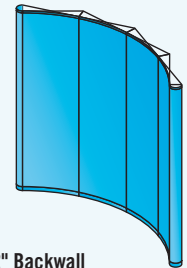

10' 92" Backwall

**10' 92"**  
Approx. 99 lbs.  
(45 kg) with cases

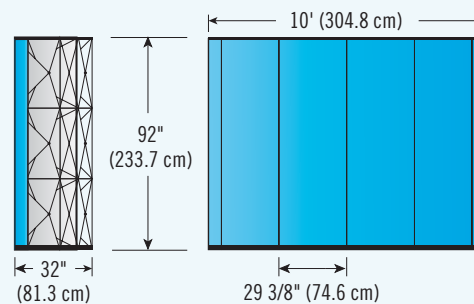

## 20' Gull Wing

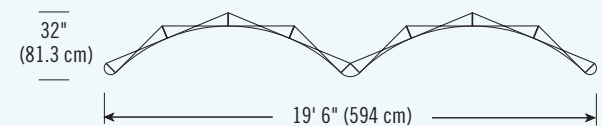

## 20' Serpentine

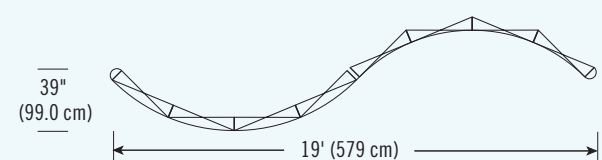

## Hard Case



## Oval Case

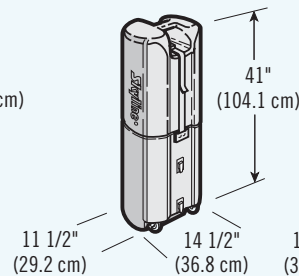

## Transporter Case

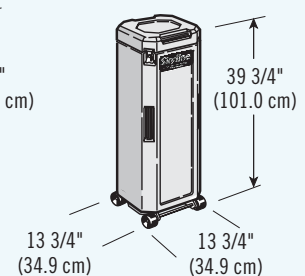

**Skyline Exhibits**  
3355 Discovery Road  
St. Paul, Minnesota 55121

1-800-328-2725  
1-651-234-6592 International  
[www.skyline.com](http://www.skyline.com)

Mirage® is a registered trademark of Skyline Exhibits

©2017 Skyline Exhibits