

This PDF template can be opened directly in Adobe Illustrator. You can design right on the "DESIGN HERE" layer, or copy each individual template into the software program of your choice.

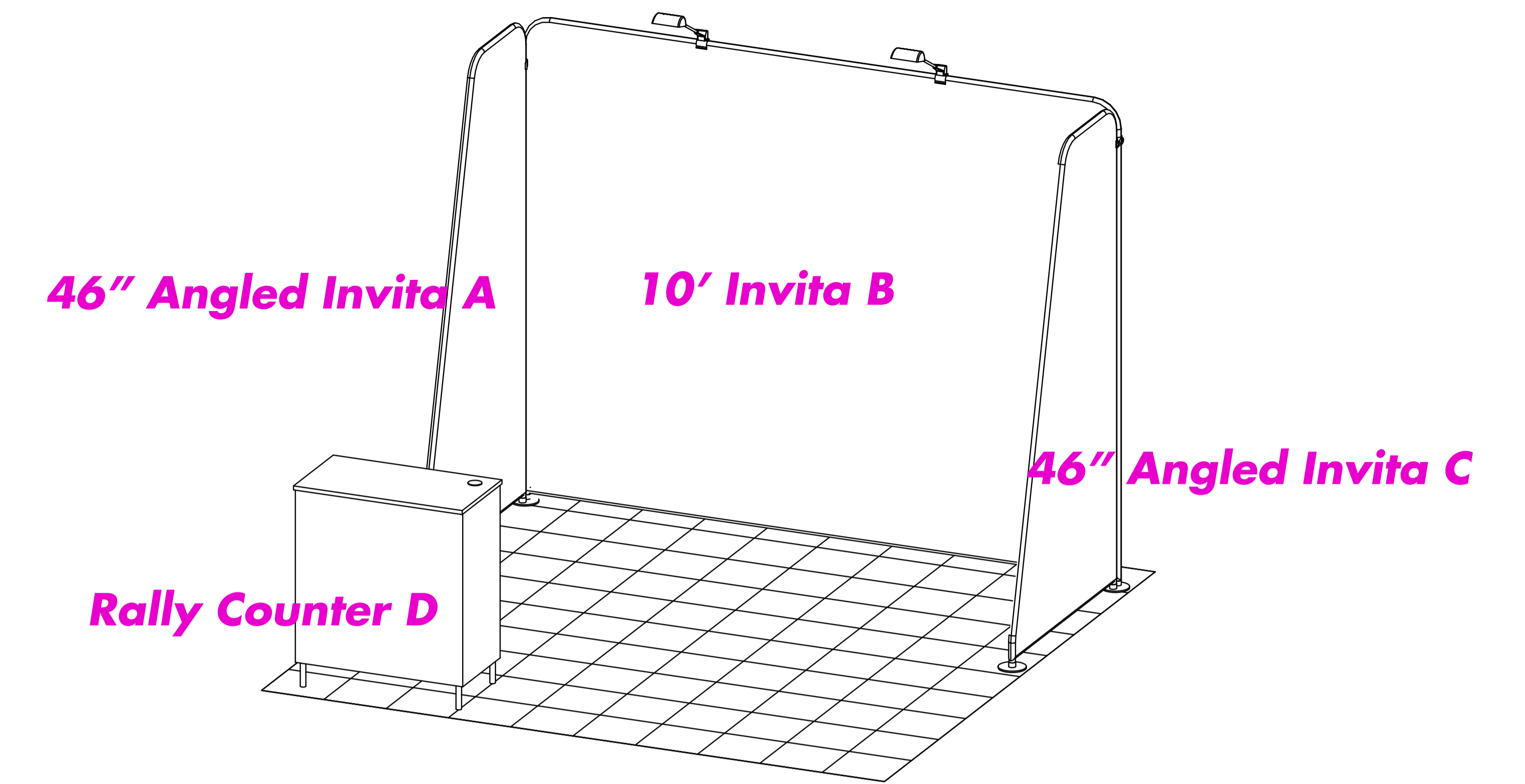

Art across the INVITA banners do NOT align and are intended to be setup as separate graphics.

Use this template to setup your 46" Angled Invita 1 display
Art Reference A

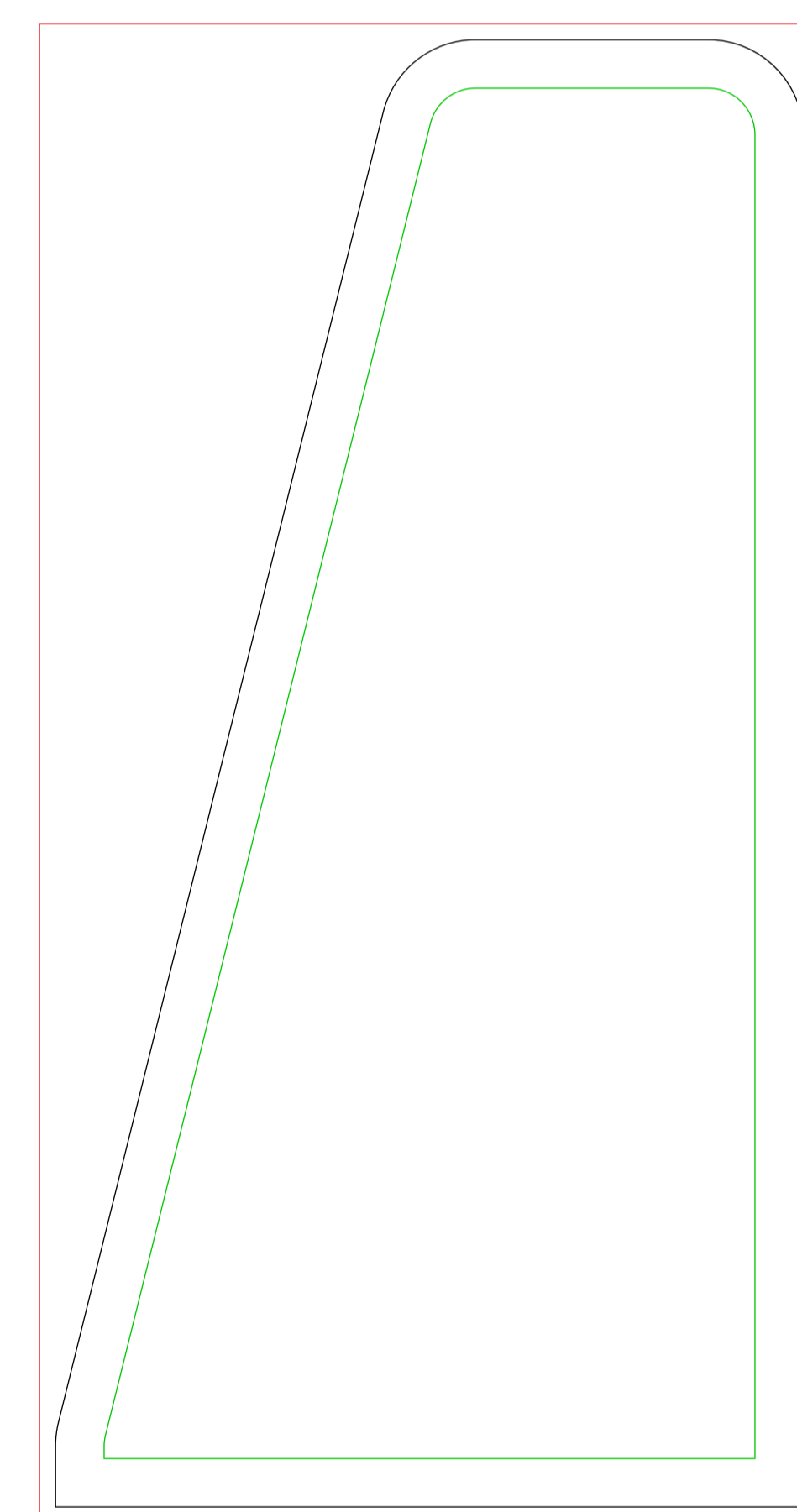

ART SIZE
48.45" X 93.06"

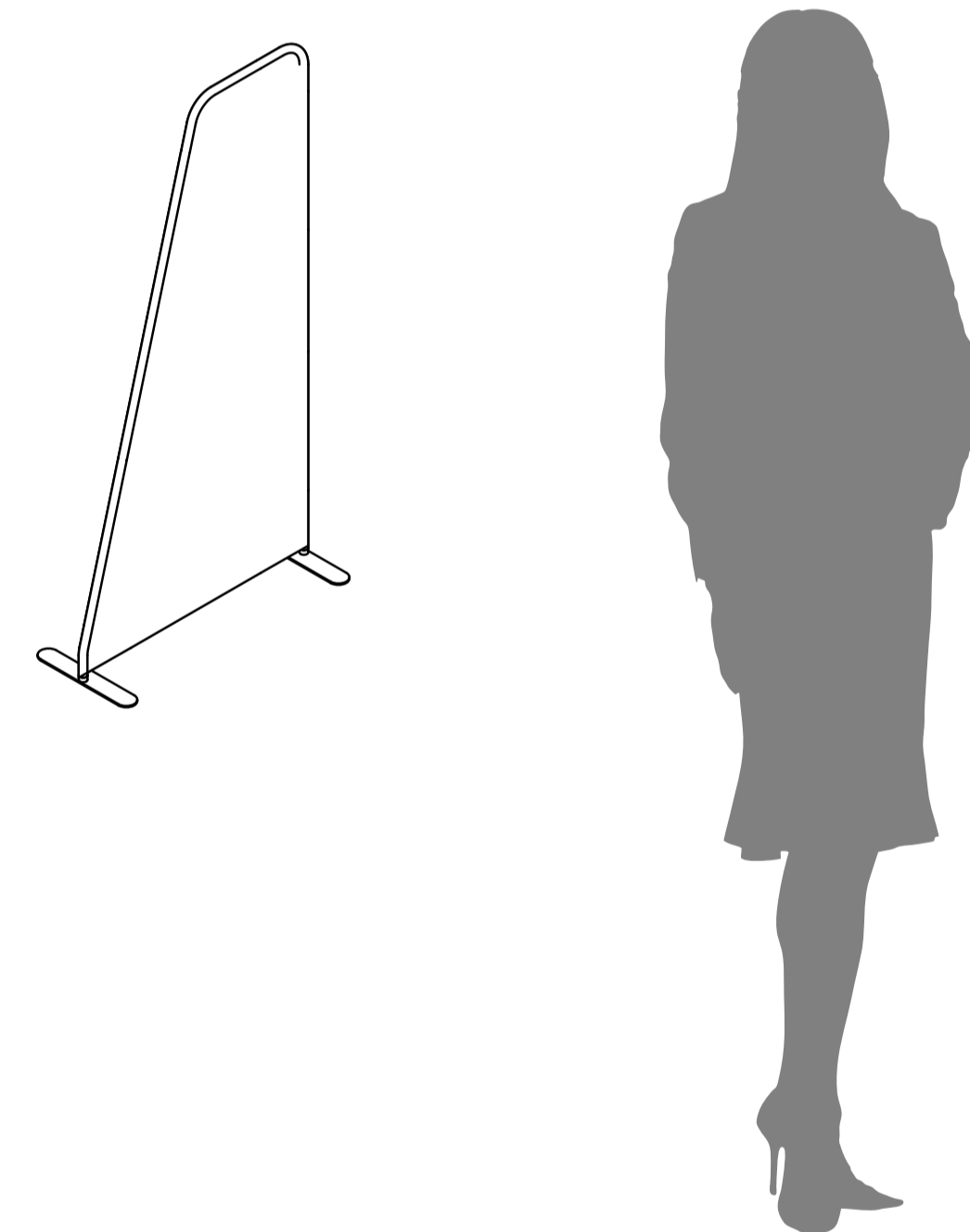

Use this template to setup your 10' Invita Display
Art Reference B



ART SIZE
117.6" X 93.07"

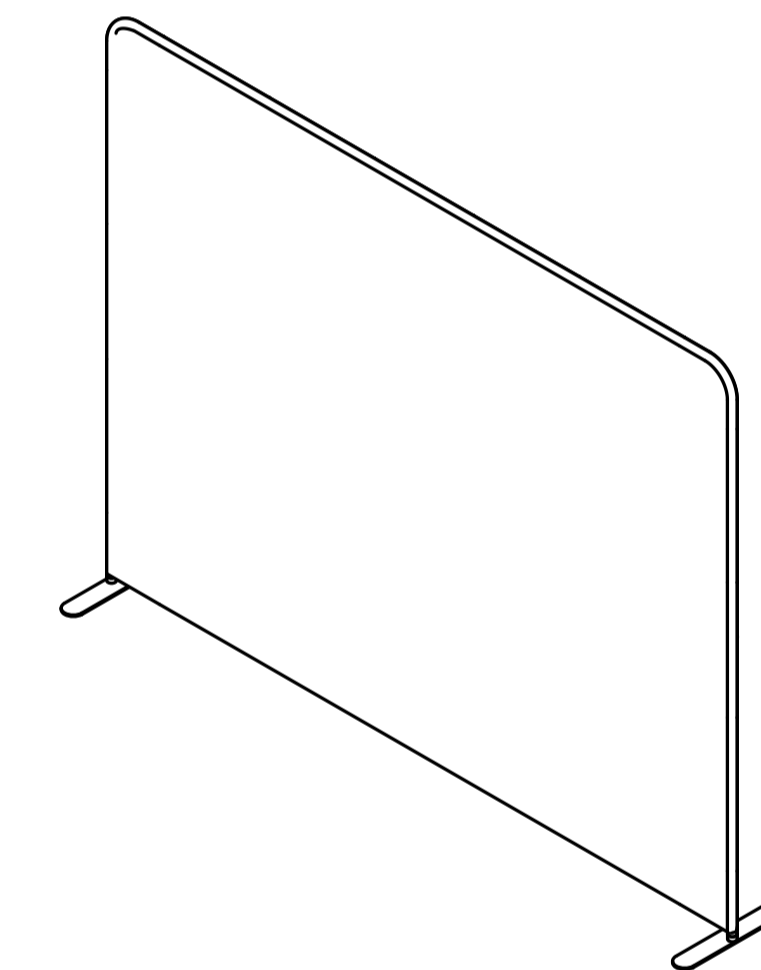

Use this template to setup your 46" Angled Invita 2 display
Art Reference C

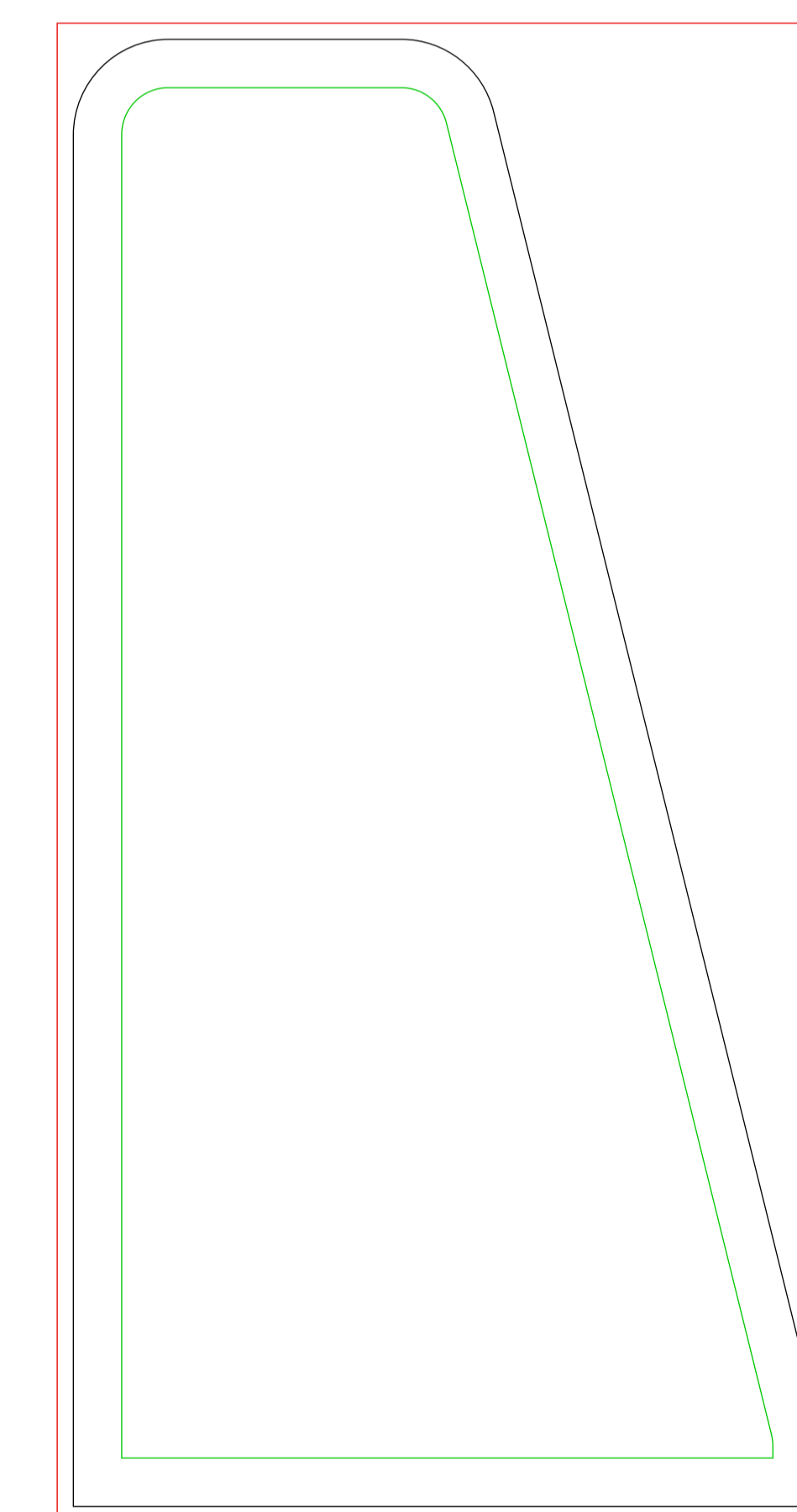

ART SIZE
48.45" X 93.06"

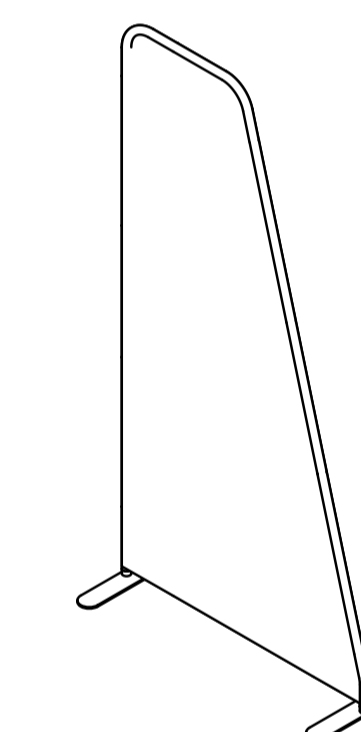

ART SIZE - This area contains all necessary bleed but, DOES NOT GET COMPLETELY CUT OFF. MUST FILL WITH BACKGROUND ART! Any art in this area can potentially be cut off, hidden or distorted in the finishing process.

SAFE ART AREA - Keep all logos, text and critical art in this area.

Please supply native packaged art files (NOT PDFs).

All necessary bleed is built into the given art size. Leave any PANTONE Colors as PMS callouts.

GENERAL ART INSTRUCTIONS:

- Do not embed images - supply linked images
- Use PhotoShop EPS links with JPEG Max Encoding for flat raster files & TIFF or PNG for layered rasters
- Resolution should be 100 ppi at final physical size
- Convert all fonts to outlined artwork
- Best Black=RGB 0-0-0 or CMYK 100-100-100-100

COLOR:

Type your Pantone colors at the red x's, and fill that color in the square to the left. If no Pantone colors are listed, the color will print "as supplied" with no guarantee to color accuracy.

| PANTONE COLOR | |
|---------------|---|
| x | x |
| x | x |
| x | x |

Use this template to setup your Rally counter
Art Reference D

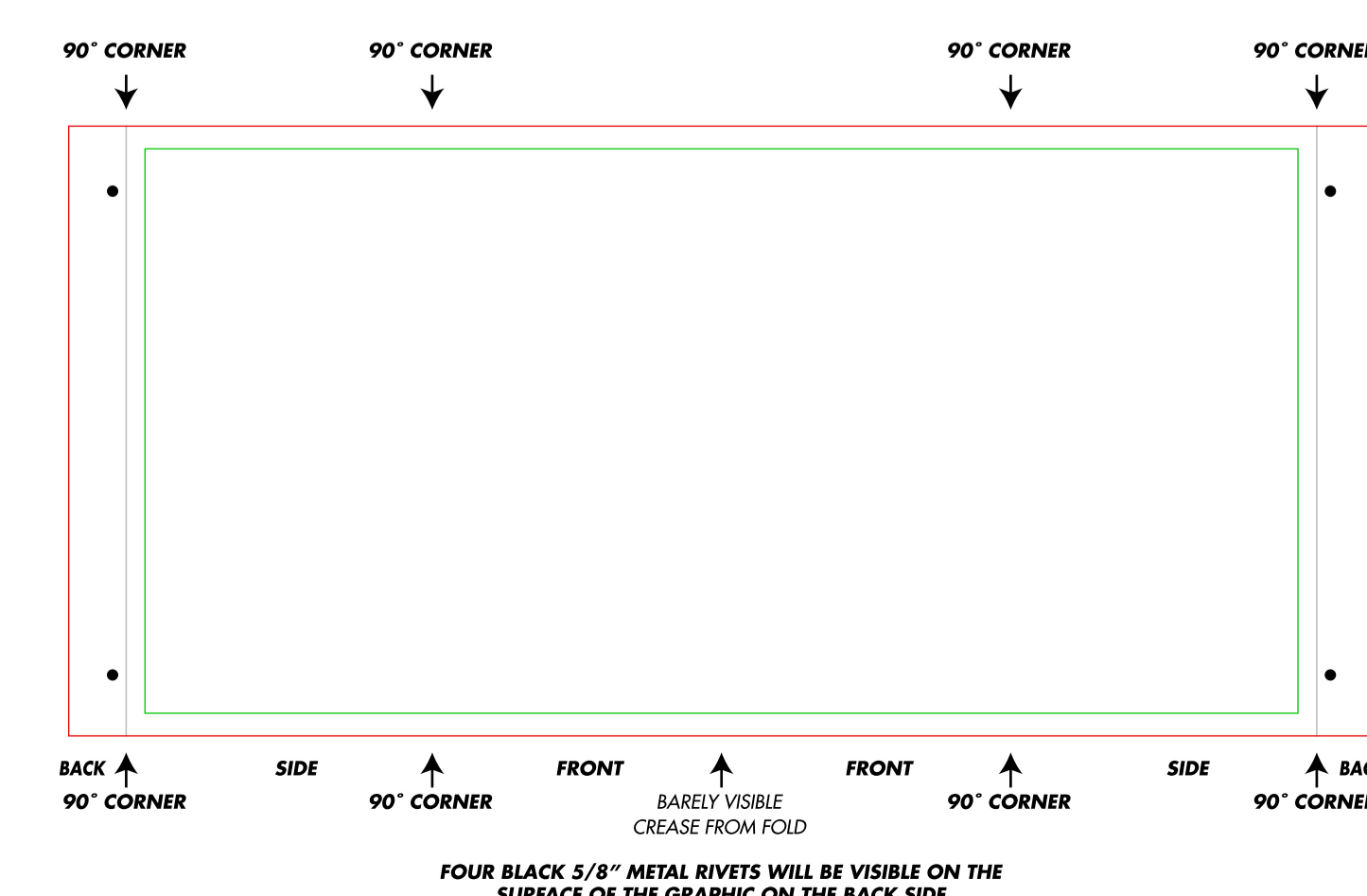
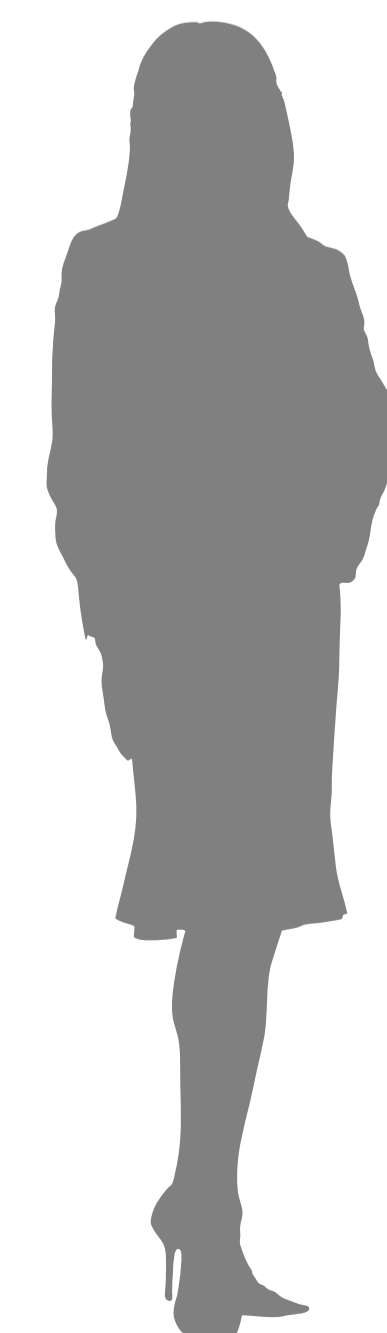

ART SIZE
71.94" X 33.63"

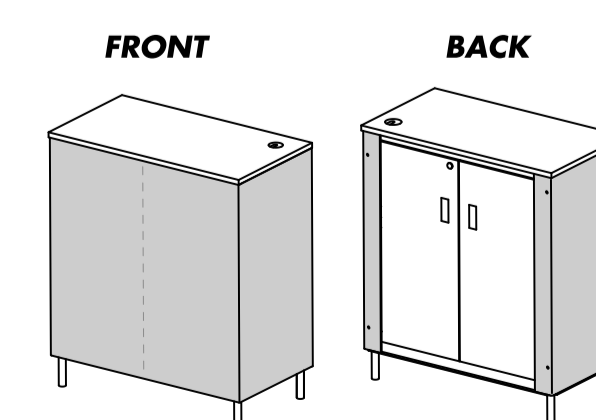

GRAPHIC WRAP FOLDS IN MIDDLE FOR SHIPPING